

MECHANICAL DIMENSIONS

IE0

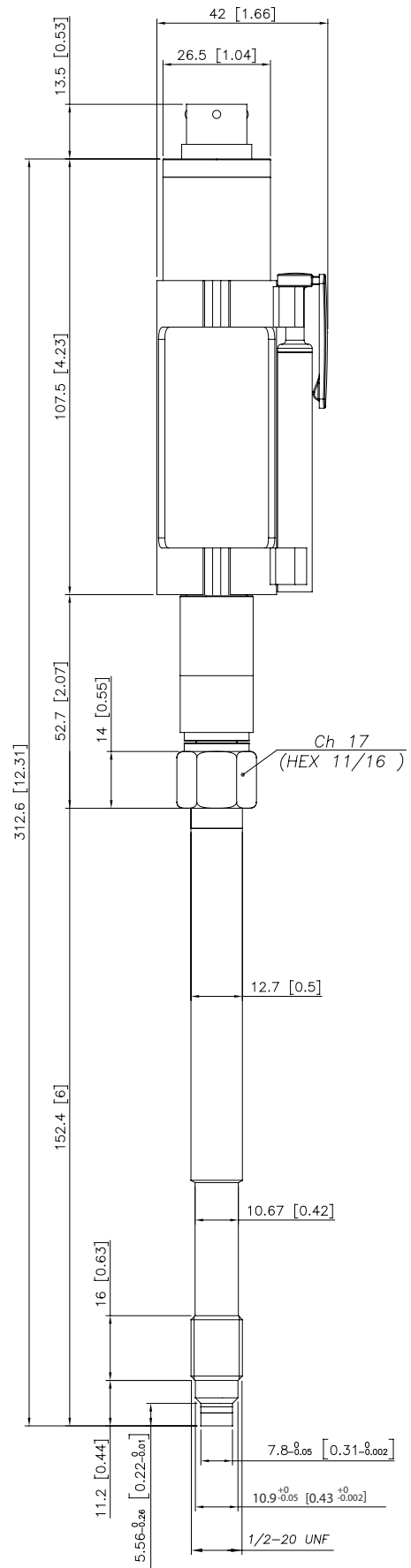
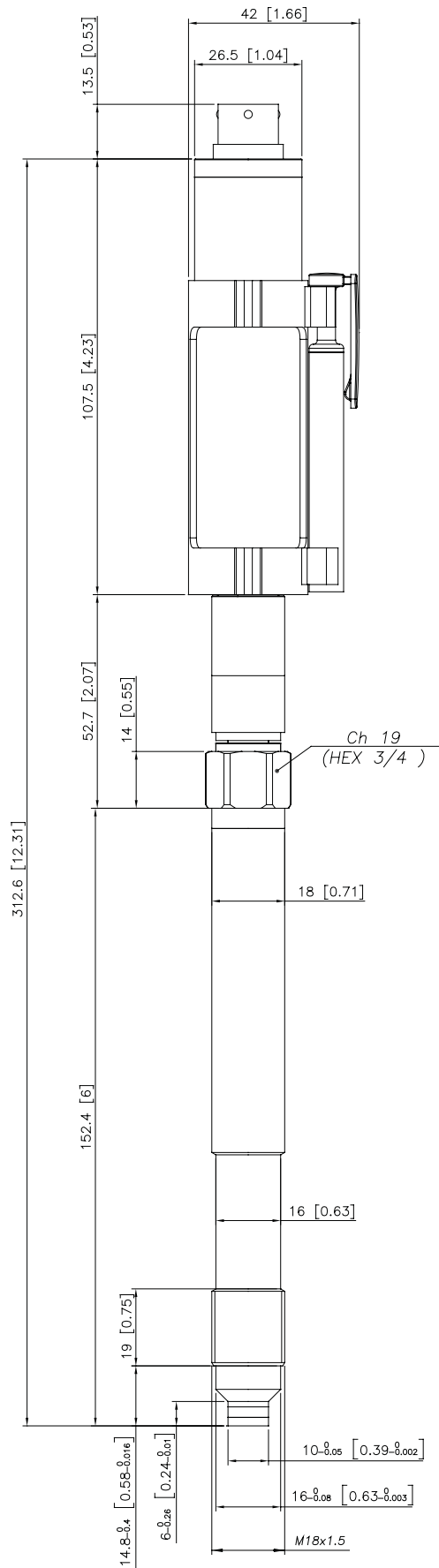

NOTE : dimensions refer to rigid stem length option “4” (153 mm – 6”)

WARNING : For installation use a maximum tightening torque of 40 Nm (355 in-lb)

MECHANICAL DIMENSIONS

IE1M

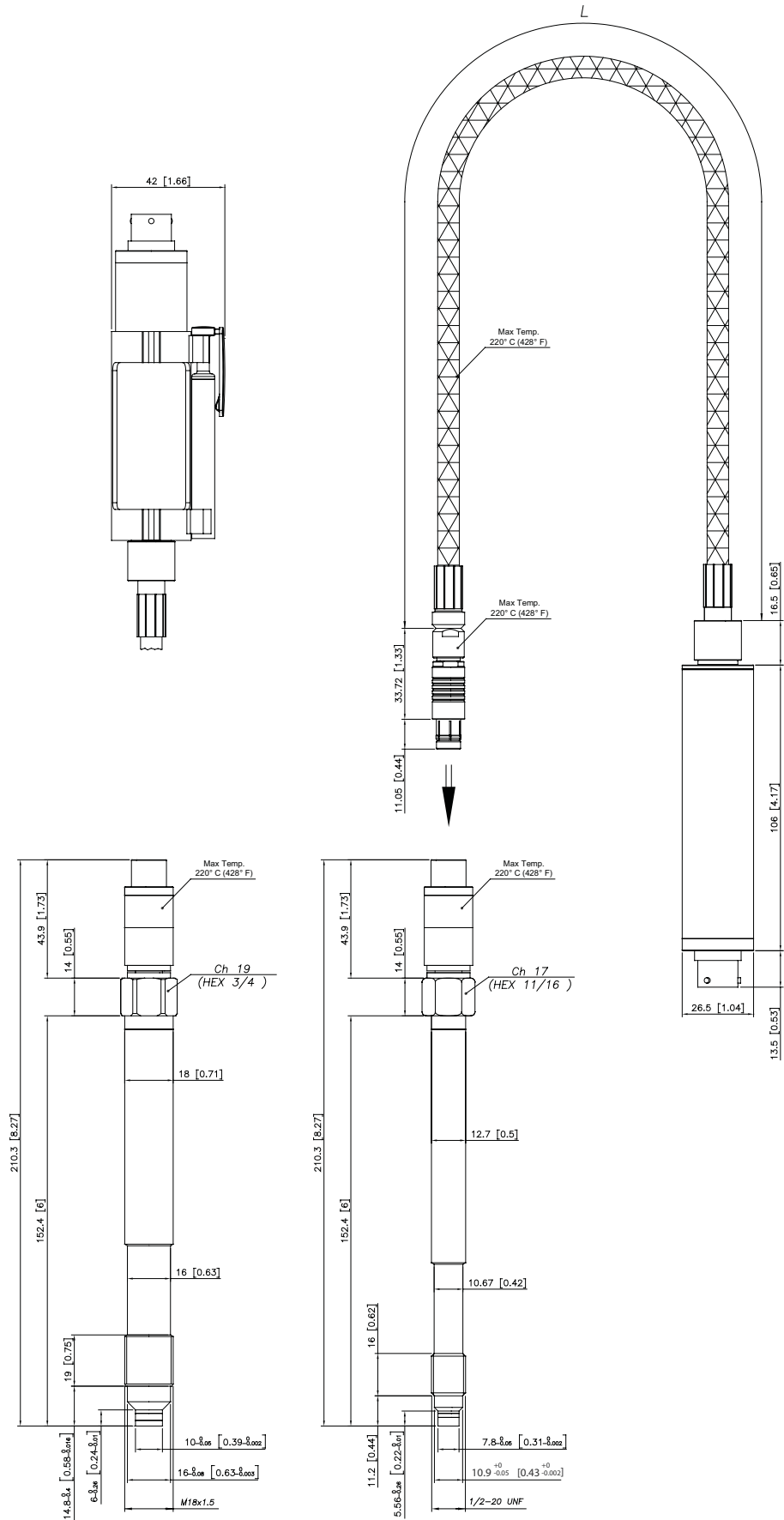

NOTE : dimensions refer to rigid stem length option "4" (153 mm – 6")

WARNING : For installation use a maximum tightening torque of 40 Nm (355 in-lb)

MECHANICAL DIMENSIONS

IE2

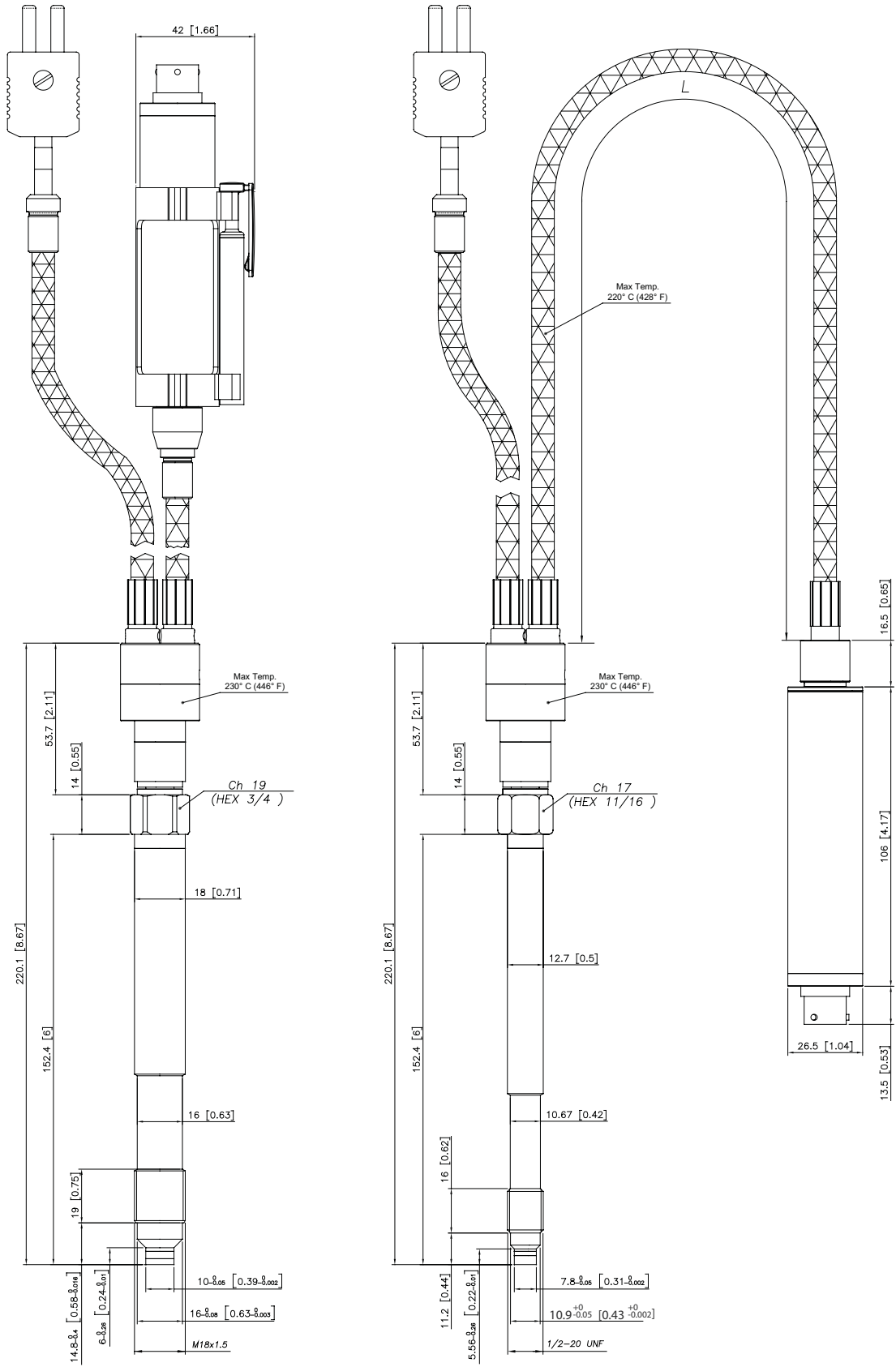

NOTE : dimensions refer to rigid stem length option "4" (153 mm – 6")

WARNING : For installation use a maximum tightening torque of 40 Nm (355 in-lb)